

Data Sheet

π 120U/ π 121U/ π 122U

FEATURES

- Ultra-low power consumption (150Kbps): 0.55mA/Channel
- High data rate: 150kbps
- High common-mode transient immunity: 250 kV/ μ s
- High robustness to radiated and conducted noise
- Isolation voltages:
 - π 12xx3x: AC 3000Vrms
 - π 12xx6x: AC 5000Vrms
- High ESD rating:
 - ESDA/JEDEC JS-001-2017
 - Human body model (HBM) \pm 8kV
- Safety and regulatory approvals:
 - UL certificate number: E494497
 - 3000Vrms/5000Vrms for 1 minute per UL 1577
 - CSA Component Acceptance Notice 5A
 - VDE certificate number: 40053041/40052896
 - DIN VDE V 0884-11:2017-01
 - $V_{IORM} = 565V$ peak/1200V peak
 - CQC certification per GB4943.1-2011
- 3 V to 5.5 V level translation
- Wide temperature range: $-40^{\circ}C$ to $125^{\circ}C$
- RoHS-compliant, NB SOIC-8, WB SOIC-16 package

APPLICATIONS

- General-purpose multichannel isolation
- Industrial field bus isolation
- Isolation Industrial automation systems
- Isolated switch mode supplies
- Isolated ADC, DAC
- Motor control

GENERAL DESCRIPTION

The π 1xxxx is a 2PaiSemi digital isolators product family that includes over hundreds of digital isolator products. By using matured standard semiconductor CMOS technology and 2PaiSemi *iDivider*[®] technology, these isolation components provide outstanding performance characteristics and reliability superior to alternatives such as optocoupler devices and other integrated isolators.

Intelligent voltage divider technology (*iDivider*[®] technology) is a new generation digital isolator technology invented by 2PaiSemi. It uses the principle of capacitor voltage divider to transmit voltage signal directly cross the isolator capacitor without signal modulation and demodulation.

The π 1xxxx isolator data channels are independent and are available in a variety of configurations with a withstand voltage rating of 1.5 kV rms to 5.0 kV rms and the data rate from DC up to 600Mbps (see the Ordering Guide). The devices operate with the

supply voltage on either side ranging from 3.0 V to 5.5 V, providing compatibility with lower voltage systems as well as enabling voltage translation functionality across the isolation barrier. The fail-safe state is available in which the outputs transition to a preset state when the input power supply is not applied.

FUNCTIONAL BLOCK DIAGRAMS

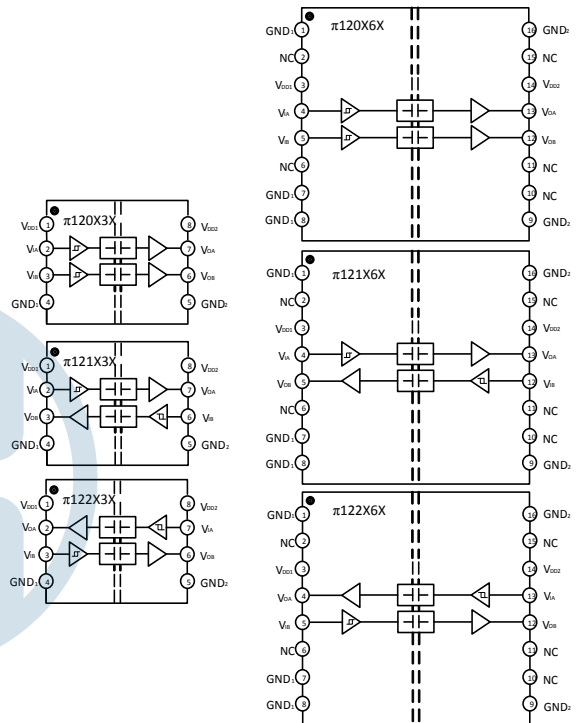

Figure 1. π 120xxx/ π 121xxx/ π 122xxx functional Block Diagram

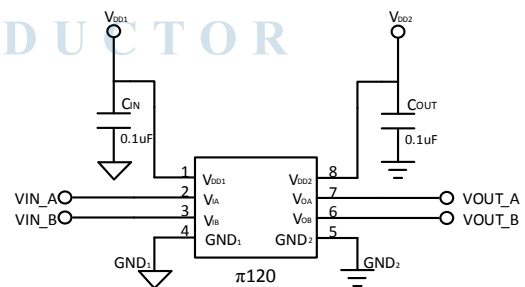

Figure 2. π 120xxx Typical Application Circuit

PIN CONFIGURATIONS AND FUNCTIONS

Table 1. π 120U3x Pin Function Descriptions

Pin No.	Name	Description
1	V _{DD1}	Supply Voltage for Isolator Side 1.
2	V _{IA}	Logic Input A.
3	V _{IB}	Logic Input B.
4	GND ₁	Ground 1. This pin is the ground reference for Isolator Side 1.
5	GND ₂	Ground 2. This pin is the ground reference for Isolator Side 2.
6	V _{OB}	Logic Output B.
7	V _{OA}	Logic Output A.
8	V _{DD2}	Supply Voltage for Isolator Side 2.

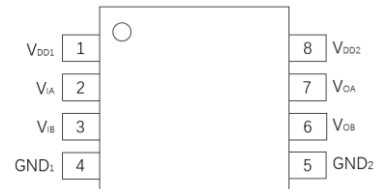

Figure 3. π 120U3x Pin Configuration

Table 2. π 121U3x Pin Function Descriptions

Pin No.	Name	Description
1	V _{DD1}	Supply Voltage for Isolator Side 1.
2	V _{IA}	Logic Input A.
3	V _{OB}	Logic Output B.
4	GND ₁	Ground 1. This pin is the ground reference for Isolator Side 1.
5	GND ₂	Ground 2. This pin is the ground reference for Isolator Side 2.
6	V _{IB}	Logic Input B.
7	V _{OA}	Logic Output A.
8	V _{DD2}	Supply Voltage for Isolator Side 2.

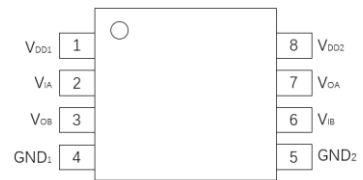

Figure 4. π 121U3x Pin Configuration

Table 3. π 122U3x Pin Function Descriptions

Pin No.	Name	Description
1	V _{DD1}	Supply Voltage for Isolator Side 1.
2	V _{OA}	Logic Output A.
3	V _{IB}	Logic Input B.
4	GND ₁	Ground 1. This pin is the ground reference for Isolator Side 1.
5	GND ₂	Ground 2. This pin is the ground reference for Isolator Side 2.
6	V _{OB}	Logic Output B.
7	V _{IA}	Logic Input A.
8	V _{DD2}	Supply Voltage for Isolator Side 2.

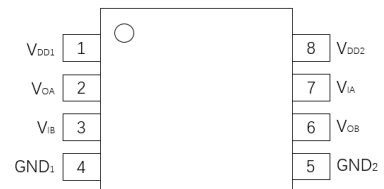

Figure 5. π 122U3x Pin Configuration

Table 4. π 120U6x Pin Function Descriptions

Pin No.	Name	Description
1	GND ₁	Ground 1. This pin is the ground reference for Isolator Side 1.
2	NC	No connect.
3	V _{DD1}	Supply Voltage for Isolator Side 1.
4	V _{IA}	Logic Input A.
5	V _{IB}	Logic Input B.
6	NC	No Connect.
7	GND ₁	Ground 1. This pin is the ground reference for Isolator Side 1.
8	GND ₁	Ground 1. This pin is the ground reference for Isolator Side 1.
9	GND ₂	Ground 2. This pin is the ground reference for Isolator Side 2.
10	NC	No Connect.
11	NC	No Connect.
12	V _{OB}	Logic Output B.
13	V _{OA}	Logic Output A.
14	V _{DD2}	Supply Voltage for Isolator Side 2.
15	NC	No Connect.
16	GND ₂	Ground 2. This pin is the ground reference for Isolator Side 2.

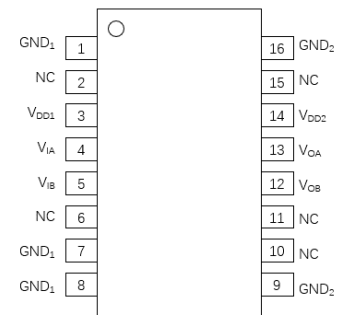

Figure 6. π 120U6x Pin Configuration

Table 5. π 121U6x Pin Function Descriptions

Pin No.	Name	Description
1	GND ₁	Ground 1. This pin is the ground reference for Isolator Side 1.
2	NC	No Connect.
3	V _{DD1}	Supply Voltage for Isolator Side 1.
4	V _{IA}	Logic Input A.
5	V _{OB}	Logic Output B.
6	NC	No Connect.
7	GND ₁	Ground 1. This pin is the ground reference for Isolator Side 1.
8	GND ₁	Ground 1. This pin is the ground reference for Isolator Side 1.
9	GND ₂	Ground 2. This pin is the ground reference for Isolator Side 2.
10	NC	No Connect.
11	NC	No Connect.
12	V _{IB}	Logic Input B.
13	V _{OA}	Logic Output A.
14	V _{DD2}	Supply Voltage for Isolator Side 2.
15	NC	No Connect.
16	GND ₂	Ground 2. This pin is the ground reference for Isolator Side 2.

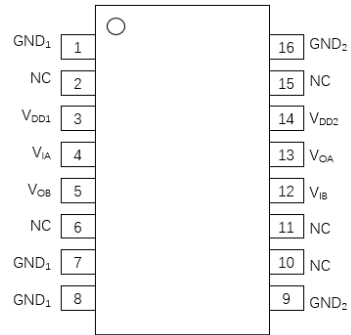

Figure 7. π 121U6x Pin Configuration

Table 6. π 122U6x Pin Function Descriptions

Pin No.	Name	Description
1	GND ₁	Ground 1. This pin is the ground reference for Isolator Side 1.
2	NC	No Connect.
3	V _{DD1}	Supply Voltage for Isolator Side 1.
4	V _{OA}	Logic Output A.
5	V _{IB}	Logic Input B.
6	NC	No Connect.
7	GND ₁	Ground 1. This pin is the ground reference for Isolator Side 1.
8	GND ₁	Ground 1. This pin is the ground reference for Isolator Side 1.
9	GND ₂	Ground 2. This pin is the ground reference for Isolator Side 2.
10	NC	No Connect.
11	NC	No Connect.
12	V _{OB}	Logic Output B.
13	V _{IA}	Logic Input A.
14	V _{DD2}	Supply Voltage for Isolator Side 2.
15	NC	No Connect.
16	GND ₂	Ground 2. This pin is the ground reference for Isolator Side 2.

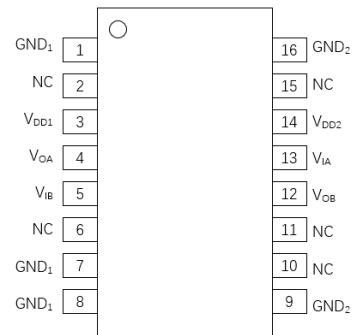

Figure 8. π 122U6x Pin Configuration

ABSOLUTE MAXIMUM RATINGS

T_A = 25°C, unless otherwise noted.

Table 7. Absolute Maximum Ratings⁴

Parameter	Rating
Supply Voltages (V _{DD1} -GND ₁ , V _{DD2} -GND ₂)	-0.5 V to +7.0 V
Input Voltages (V _{IA} , V _{IB}) ¹	-0.5 V to V _{DDx} + 0.5 V
Output Voltages (V _{OA} , V _{OB}) ¹	-0.5 V to V _{DDx} + 0.5 V
Average Output Current per Pin ² Side 1 Output Current (I _{O1})	-10 mA to +10 mA
Average Output Current per Pin ² Side 2 Output Current (I _{O2})	-10 mA to +10 mA
Common-Mode Transients Immunity ³	-300 kV/μs to +300 kV/μs
Storage Temperature (T _{ST}) Range	-65°C to +150°C
Ambient Operating Temperature (T _A) Range	-40°C to +125°C

Notes:

¹ V_{DDx} is the side voltage power supply V_{DD}, where x = 1 or 2.

² See Figure 9 for the maximum rated current values for various temperatures.

³ See Figure 16 for Common-mode transient immunity (CMTI) measurement.

⁴ Stresses at or above those listed under Absolute Maximum Ratings may cause permanent damage to the device. These are stress rating only; functional operation of the device at these or any other conditions above those indicated in the operational section of this specification is not implied. Operation beyond the maximum operating conditions for extended periods may affect product reliability.

RECOMMENDED OPERATING CONDITIONS

Table 8. Recommended Operating Conditions

Parameter	Symbol	Min	Typ	Max	Unit
Supply Voltage	V_{DDx}^1	3		5.5	V
High Level Input Signal Voltage	V_{IH}	$0.7 \cdot V_{DDx}^1$		V_{DDx}^1	V
Low Level Input Signal Voltage	V_{IL}	0		$0.3 \cdot V_{DDx}^1$	V
High Level Output Current	I_{OH}	-6			mA
Low Level Output Current	I_{OL}			6	mA
Data Rate		0		150	Kbps
Junction Temperature	T_J	-40		150	°C
Ambient Operating Temperature	T_A	-40		125	°C

Notes:

¹ V_{DDx} is the side voltage power supply V_{DD} , where $x = 1$ or 2 .

Truth Tables

Table 9. $\pi 120xxx/\pi 121xxx/\pi 122xxx$ Truth Table

V_{ix} Input ¹	V_{DDI} State ¹	V_{DDO} State ¹	Default Low V_{Ox} Output ¹	Default High V_{Ox} Output ¹	Test Conditions /Comments
Low	Powered ²	Powered ²	Low	Low	Normal operation
High	Powered ²	Powered ²	High	High	Normal operation
Open	Powered ²	Powered ²	Low	High	Default output
Don't Care ⁴	Unpowered ³	Powered ²	Low	High	Default output ⁵
Don't Care ⁴	Powered ²	Unpowered ³	High Impedance	High Impedance	

Notes:

¹ V_{ix}/V_{Ox} are the input/output signals of a given channel (A or B). V_{DDI}/V_{DDO} are the supply voltages on the input/output signal sides of this given channel.

² Powered means $V_{DDx} \geq 2.95$ V

³ Unpowered means $V_{DDx} < 2.30$ V

⁴ Input signal (V_{ix}) must be in a low state to avoid powering the given V_{DDI} through its ESD protection circuitry.

⁵ If the V_{DDI} goes into unpowered status, the channel outputs the default logic signal after around 1 μ s. If the V_{DDI} goes into powered status, the channel outputs the input status logic signal after around 3 μ s.

SPECIFICATIONS

ELECTRICAL CHARACTERISTICS

Table 10. $\pi 12xU3x$ Switching Specifications

$V_{DD1} - V_{GND1} = V_{DD2} - V_{GND2} = 3.3V_{DC} \pm 10\%$ or $5V_{DC} \pm 10\%$, $T_A = 25^\circ\text{C}$, unless otherwise noted.

Parameter	Symbol	Min	Typ	Max	Unit	Test Conditions/Comments
Minimum Pulse Width	PW			6.5	us	Within pulse width distortion (PWD) limit
Maximum Data Rate		150			Kbps	Within PWD limit
Propagation Delay Time ¹	t_{pHL}, t_{pLH}		3.0	4.5	us	@ $5V_{DC}$ supply
			3.2	4.8	us	@ $3.3V_{DC}$ supply
Pulse Width Distortion	PWD	0	0.02	0.2	us	The max different time between t_{pHL} and t_{pLH} @ $5V_{DC}$ supply. And The value is $ t_{pHL} - t_{pLH} $
		0	0.02	0.2	us	The max different time between t_{pHL} and t_{pLH} @ $3.3V_{DC}$ supply. And The value is $ t_{pHL} - t_{pLH} $

Parameter	Symbol	Min	Typ	Max	Unit	Test Conditions/Comments
Output Signal Rise/Fall Time ⁴	t_r/t_f		1.5		ns	See Figure 13.
Common-Mode Transient Immunity ³	CMTI	250			kV/ μ s	$V_{IN} = V_{DDx}^2$ or 0V, $V_{CM} = 1000$ V.
ESD (HBM - Human body model)	ESD		± 8		kV	

Notes:

¹ t_{pLH} = low-to-high propagation delay time, t_{pHL} = high-to-low propagation delay time. See Figure 14.² V_{DDx} is the side voltage power supply V_{DD} , where x = 1 or 2.³ See Figure 16 for Common-mode transient immunity (CMTI) measurement.⁴ t_r means is the time from 10% amplitude to 90% amplitude of the rising edge of the signal, t_f means is the time from 90% amplitude to 10% amplitude of the falling edge of the signal.Table 11. $\pi 12xU6x$ Switching Specifications $V_{DD1} - V_{GND1} = V_{DD2} - V_{GND2} = 3.3V_{DC} \pm 10\%$ or $5V_{DC} \pm 10\%$, $T_A = 25^\circ C$, unless otherwise noted.

Parameter	Symbol	Min	Typ	Max	Unit	Test Conditions/Comments
Minimum Pulse Width	PW			6.5	us	Within pulse width distortion (PWD) limit
Maximum Data Rate		150			Kbps	Within PWD limit
Propagation Delay Time ¹	t_{pHL}, t_{pLH}		2.5	4.5	us	@ 5V _{DC} supply
			2.7	4.8	us	@ 3.3V _{DC} supply
Pulse Width Distortion	PWD	0	0.02	0.2	us	The max different time between t_{pHL} and t_{pLH} @ 5V _{DC} supply. And The value is $ t_{pHL} - t_{pLH} $
		0	0.02	0.2	us	The max different time between t_{pHL} and t_{pLH} @ 3.3V _{DC} supply. And The value is $ t_{pHL} - t_{pLH} $
Output Signal Rise/Fall Time ⁴	t_r/t_f		1.5		ns	See Figure 13.
Common-Mode Transient Immunity ³	CMTI	250			kV/ μ s	$V_{IN} = V_{DDx}^2$ or 0V, $V_{CM} = 1000$ V.
ESD (HBM - Human body model)	ESD		± 8		kV	

Notes:

¹ t_{pLH} = low-to-high propagation delay time, t_{pHL} = high-to-low propagation delay time. See Figure 14.² V_{DDx} is the side voltage power supply V_{DD} , where x = 1 or 2.³ See Figure 16 for Common-mode transient immunity (CMTI) measurement.⁴ t_r means is the time from 10% amplitude to 90% amplitude of the rising edge of the signal, t_f means is the time from 90% amplitude to 10% amplitude of the falling edge of the signal.

Table 12. DC Specifications

 $V_{DD1} - V_{GND1} = V_{DD2} - V_{GND2} = 3.3V_{DC} \pm 10\%$ or $5V_{DC} \pm 10\%$, $T_A = 25^\circ C$, unless otherwise noted.

Parameter	Symbol	Min	Typ	Max	Unit	Test Conditions/Comments
Rising Input Signal Voltage Threshold	V_{IT+}		$0.6 * V_{DDx}^1$	$0.7 * V_{DDx}^1$	V	
Falling Input Signal Voltage Threshold	V_{IT-}	$0.3 * V_{DDx}^1$	$0.4 * V_{DDx}^1$		V	
High Level Output Voltage	V_{OH}^1	$V_{DDx} - 0.1$	V_{DDx}		V	-20 μ A output current
		$V_{DDx} - 0.2$	$V_{DDx} - 0.1$		V	-2 mA output current
Low Level Output Voltage	V_{OL}		0	0.1	V	20 μ A output current
			0.1	0.2	V	2 mA output current
Input Current per Signal Channel	I_{IN}	-10	0.5	10	μ A	0 V \leq Signal voltage $\leq V_{DDx}^1$
V_{DDx}^1 Undervoltage Rising Threshold	V_{DDxUV+}	2.45	2.75	2.95	V	
V_{DDx}^1 Undervoltage Falling Threshold	V_{DDxUV-}	2.30	2.60	2.75	V	
V_{DDx}^1 Hysteresis	V_{DDxUVH}		0.15		V	

Notes:

¹ V_{DDx} is the side voltage power supply V_{DD} , where x = 1 or 2.

Table 13. Quiescent Supply Current

 $V_{DD1} - V_{GND1} = V_{DD2} - V_{GND2} = 3.3V_{DC} \pm 10\%$ or $5V_{DC} \pm 10\%$, $T_A = 25^\circ C$, $C_L = 0$ pF, unless otherwise noted.

Part	Symbol	Min	Typ	Max	Unit	Test Conditions	
						Supply voltage	Input signal
π120U3x	I _{DD1} (α)	0.15	0.19	0.25	mA	5V _{DC}	VI=0V for π12xUx1
	I _{DD2} (α)	0.71	0.89	1.15	mA		VI=5V for π12xUx0
	I _{DD1} (α)	0.06	0.08	0.10	mA	3.3V _{DC}	VI=5V for π12xUx1
	I _{DD2} (α)	0.77	0.96	1.25	mA		VI=0V for π12xUx0
	I _{DD1} (α)	0.11	0.14	0.18	mA		VI=0V for π12xUx1
	I _{DD2} (α)	0.70	0.87	1.13	mA		VI=3.3V for π12xUx0
π121U3x	I _{DD1} (α)	0.43	0.54	0.70	mA	5V _{DC}	VI=0V for π12xUx1
	I _{DD2} (α)	0.43	0.54	0.70	mA		VI=5V for π12xUx0
	I _{DD1} (α)	0.41	0.52	0.67	mA	3.3V _{DC}	VI=5V for π12xUx1
	I _{DD2} (α)	0.41	0.52	0.67	mA		VI=0V for π12xUx0
	I _{DD1} (α)	0.40	0.51	0.66	mA		VI=0V for π12xUx1
	I _{DD2} (α)	0.41	0.51	0.66	mA		VI=3.3V for π12xUx0
π122U3x	I _{DD1} (α)	0.43	0.54	0.70	mA	5V _{DC}	VI=0V for π12xUx1
	I _{DD2} (α)	0.43	0.54	0.70	mA		VI=5V for π12xUx0
	I _{DD1} (α)	0.41	0.52	0.67	mA	3.3V _{DC}	VI=5V for π12xUx1
	I _{DD2} (α)	0.41	0.52	0.67	mA		VI=0V for π12xUx0
	I _{DD1} (α)	0.41	0.51	0.66	mA		VI=0V for π12xUx1
	I _{DD2} (α)	0.41	0.51	0.66	mA		VI=3.3V for π12xUx0
π120U6x	I _{DD1} (α)	0.15	0.34	0.42	mA	5V _{DC}	VI=0V for π12xUx1
	I _{DD2} (α)	0.71	1.08	1.40	mA		VI=5V for π12xUx0
	I _{DD1} (α)	0.06	0.11	0.14	mA	3.3V _{DC}	VI=5V for π12xUx1
	I _{DD2} (α)	0.77	1.16	1.52	mA		VI=0V for π12xUx0
	I _{DD1} (α)	0.11	0.22	0.28	mA		VI=0V for π12xUx1
	I _{DD2} (α)	0.70	1.04	1.35	mA		VI=3.3V for π12xUx0
π121U6x	I _{DD1} (α)	0.43	0.67	0.87	mA	5V _{DC}	VI=0V for π12xUx1
	I _{DD2} (α)	0.43	0.67	0.87	mA		VI=5V for π12xUx0
	I _{DD1} (α)	0.41	0.60	0.78	mA	3.3V _{DC}	VI=5V for π12xUx1
	I _{DD2} (α)	0.41	0.60	0.78	mA		VI=0V for π12xUx0
	I _{DD1} (α)	0.40	0.59	0.77	mA		VI=0V for π12xUx1
	I _{DD2} (α)	0.41	0.59	0.77	mA		VI=3.3V for π12xUx0
π122U6x	I _{DD1} (α)	0.43	0.67	0.87	mA	5V _{DC}	VI=0V for π12xUx1
	I _{DD2} (α)	0.43	0.67	0.87	mA		VI=5V for π12xUx0
	I _{DD1} (α)	0.41	0.60	0.78	mA	3.3V _{DC}	VI=5V for π12xUx1
	I _{DD2} (α)	0.41	0.60	0.78	mA		VI=0V for π12xUx0
	I _{DD1} (α)	0.41	0.59	0.77	mA		VI=0V for π12xUx1
	I _{DD2} (α)	0.41	0.59	0.77	mA		VI=3.3V for π12xUx0

Part	Symbol	Min	Typ	Max	Unit	Test Conditions	
						Supply voltage	Input signal
	I _{DD1} (Q)	0.41	0.58	0.75	mA		V _I =3.3V for π 12xUx1
	I _{DD2} (Q)	0.41	0.58	0.75	mA		V _I =0V for π 12xUx0

Table 14.Total Supply Current vs. Data Throughput (CL = 0 pF)

 $V_{DD1} - V_{GND1} = V_{DD2} - V_{GND2} = 3.3V_{DC} \pm 10\%$ or $5V_{DC} \pm 10\%$, $T_A = 25^\circ C$, $C_L = 0$ pF, unless otherwise noted.

Part	Symbol	2 Kbps			50Kbps			150Kbps			Unit	Supply voltage
		Min	Typ	Max	Min	Typ	Max	Min	Typ	Max		
π 120U3x	I _{DD1}	0.13	0.20		0.13	0.20		0.13	0.20		mA	5V _{DC}
	I _{DD2}	0.92	1.38		0.93	1.40		0.94	1.41			
π 120U3x	I _{DD1}	0.10	0.15		0.10	0.15		0.10	0.15		mA	3.3V _{DC}
	I _{DD2}	0.91	1.37		0.91	1.37		0.92	1.38			
π 121U3x	I _{DD1}	0.53	0.79		0.53	0.80		0.54	0.80		mA	5V _{DC}
	I _{DD2}	0.53	0.80		0.53	0.80		0.54	0.81			
π 121U3x	I _{DD1}	0.51	0.76		0.51	0.77		0.51	0.77		mA	3.3V _{DC}
	I _{DD2}	0.51	0.77		0.51	0.77		0.51	0.77			
π 122U3x	I _{DD1}	0.53	0.80		0.53	0.80		0.54	0.81		mA	5V _{DC}
	I _{DD2}	0.53	0.80		0.53	0.80		0.54	0.81			
π 122U3x	I _{DD1}	0.51	0.77		0.51	0.77		0.51	0.77		mA	3.3V _{DC}
	I _{DD2}	0.51	0.77		0.51	0.77		0.51	0.77			
π 120U6x	I _{DD1}	0.21	0.31		0.21	0.31		0.21	0.32		mA	5V _{DC}
	I _{DD2}	1.07	1.61		1.08	1.62		1.09	1.63			
π 120U6x	I _{DD1}	0.15	0.23		0.15	0.23		0.15	0.23		mA	3.3V _{DC}
	I _{DD2}	1.05	1.57		1.05	1.57		1.05	1.58			
π 121U6x	I _{DD1}	0.73	1.10		0.76	1.14		0.79	1.18		mA	5V _{DC}
	I _{DD2}	0.73	1.10		0.76	1.14		0.79	1.18			
π 121U6x	I _{DD1}	0.65	0.97		0.66	0.99		0.69	1.03		mA	3.3V _{DC}
	I _{DD2}	0.65	0.97		0.66	0.99		0.69	1.03			
π 122U6x	I _{DD1}	0.73	1.10		0.76	1.14		0.79	1.18		mA	5V _{DC}
	I _{DD2}	0.73	1.10		0.76	1.14		0.79	1.18			
π 122U6x	I _{DD1}	0.65	0.97		0.66	0.99		0.69	1.03		mA	3.3V _{DC}
	I _{DD2}	0.65	0.97		0.66	0.99		0.69	1.03			

INSULATION AND SAFETY RELATED SPECIFICATIONS

Table 15.Insulation Specifications

Parameter	Symbol	Value		Unit	Test Conditions/Comments
		π 12xU3x	π 12xU6x		
Rated Dielectric Insulation Voltage		3000	5000	V rms	1-minute duration
Minimum External Air Gap (Clearance)	L (CLR)	≥4	≥8	mm	Measured from input terminals to output terminals, shortest distance through air
Minimum External Tracking (Creepage)	L (CRP)	≥4	≥8	mm	Measured from input terminals to output terminals, shortest distance path along body
Minimum Internal Gap (Internal Clearance)		≥11	≥21	μm	Insulation distance through insulation

Parameter	Symbol	Value		Unit	Test Conditions/Comments
		$\pi 12xU3x$	$\pi 12xU6x$		
Tracking Resistance (Comparative Tracking Index)	CTI	>400	>400	V	DIN EN 60112 (VDE 0303-11):2010-05 IEC 60112:2003 + A1:2009
Material Group		II	II		

PACKAGE CHARACTERISTICS

Table 16. Package Characteristics

Parameter	Symbol	Typical Value		Unit	Test Conditions/Comments
		$\pi 12xU3x$	$\pi 12xU6x$		
Resistance (Input to Output) ¹	R _{IO}	10 ¹¹	10 ¹¹	Ω	
Capacitance (Input to Output) ¹	C _{IO}	1.5	1.5	pF	@1MHz
Input Capacitance ²	C _I	3	3	pF	@1MHz
IC Junction to Ambient Thermal Resistance	θ_{JA}	100	45	°C/W	Thermocouple located at center of package underside

Notes:

¹The device is considered a 2-terminal device; Short-circuit all terminals on the VDD1 side as one terminal, and short-circuit all terminals on the VDD2 side as the other terminal.

²Testing from the input signal pin to ground.

REGULATORY INFORMATION

See Table 17 for details regarding recommended maximum working voltages for specific cross isolation waveforms and insulation levels.

Table 17. Regulatory

Regulatory	$\pi 12xU3x$	$\pi 12xU6x$
UL	Recognized under UL 1577 Component Recognition Program ¹ Single Protection, 3000 V rms Isolation Voltage File (E494497)	Recognized under UL 1577 Component Recognition Program ¹ Single Protection, 5000V rms Isolation Voltage File (E494497)
VDE	DIN VDE V 0884-11:2017-01 ² Basic insulation, V _{IORM} = 565V peak, V _{IOSM} = 3615 V peak File (40053041)	DIN VDE V 0884-11:2017-01 ² Basic insulation, V _{IORM} = 1200 V peak, V _{IOSM} = 5000 V peak File (40052896)
CQC	Certified under CQC11-471543-2012 and GB4943.1-2011 Basic insulation at 500 V rms (707 V peak) working voltage Reinforced insulation at 250 V rms (353 V peak) NB SOIC-8 File (CQC20001260211)	Certified under CQC11-471543-2012 and GB4943.1-2011 Basic insulation at 845 V rms (1200 V peak) working voltage Reinforced insulation at 422 V rms (600 V peak) WB SOIC-16 File (CQC20001260258)

Notes:

¹ In accordance with UL 1577, each $\pi 120U3x/\pi 121U3x/\pi 122U3x$ is proof tested by applying an insulation test voltage ≥ 3600 V rms for 1 sec; each $\pi 120U6x/\pi 121U6x/\pi 122U6x$ is proof tested by applying an insulation test voltage ≥ 6000 V rms for 1 sec

² In accordance with DIN V VDE V 0884-11, each $\pi 120U3x/\pi 121U3x/\pi 122U3x$ is proof tested by applying an insulation test voltage ≥ 848 V peak for 1 sec (partial discharge detection limit = 5 pC); each $\pi 120U6x/\pi 121U6x/\pi 122U6x$ is proof tested by ≥ 1800 V peak for 1 sec.

DIN V VDE V 0884-11 (VDE V 0884-11) INSULATION CHARACTERISTICS

Table 18. VDE Insulation Characteristics

Description	Test Conditions/Comments	Symbol	Characteristic		Unit
			$\pi 12xU3x$	$\pi 12xU6x$	
Installation Classification per DIN VDE 0110 For Rated Mains Voltage ≤ 150 V rms For Rated Mains Voltage ≤ 300 V rms For Rated Mains Voltage ≤ 400 V rms			I to IV I to III I to III	I to IV I to III I to III	
Climatic Classification			40/105/21	40/105/21	
Pollution Degree per DIN VDE 0110, Table 1			2	2	
Maximum repetitive peak isolation voltage		V _{IORM}	565	1200	V peak

Description	Test Conditions/Comments	Symbol	Characteristic		Unit
			$\pi 12xU3x$	$\pi 12xU6x$	
Input to Output Test Voltage, Method B1	$V_{IORM} \times 1.5 = V_{pd(m)}$, 100% production test, $t_{ini} = t_m = 1$ sec, partial discharge < 5 pC	$V_{pd(m)}$	848	1800	V peak
Input to Output Test Voltage, Method A After Environmental Tests Subgroup 1 After Input and/or Safety Test Subgroup 2 and Subgroup 3	$V_{IORM} \times 1.3 = V_{pd(m)}$, $t_{ini} = 60$ sec, $t_m = 10$ sec, partial discharge < 5 pC	$V_{pd(m)}$	735	1560	V peak
	$V_{IORM} \times 1.2 = V_{pd(m)}$, $t_{ini} = 60$ sec, $t_m = 10$ sec, partial discharge < 5 pC	$V_{pd(m)}$	678	1440	V peak
Highest Allowable Overvoltage		V_{IOTM}	4200	7071	V peak
Surge Isolation Voltage Basic	Basic insulation, 1.2/50 μ s combination wave, $V_{TEST} = 1.3 \times V_{IOSM}$ (qualification) ¹	V_{IOSM}	3615	5000	V peak
Safety Limiting Values	Maximum value allowed in the event of a failure (see Figure 9)				
Maximum safety Temperature		T_S	150	150	°C
Maximum Power Dissipation at 25°C		P_S	1.25	2.78	W
Insulation Resistance at T_S	$V_{IO} = 500$ V	R_S	>10 ⁹	>10 ⁹	Ω

Notes:
¹In accordance with DIN V VDE V 0884-11, $\pi 1xxx3x$ is proof tested by applying a surge isolation voltage 4700 V, $\pi 1xxx6x$ is proof tested by applying a surge isolation voltage 6500 V.

Typical Thermal Characteristic

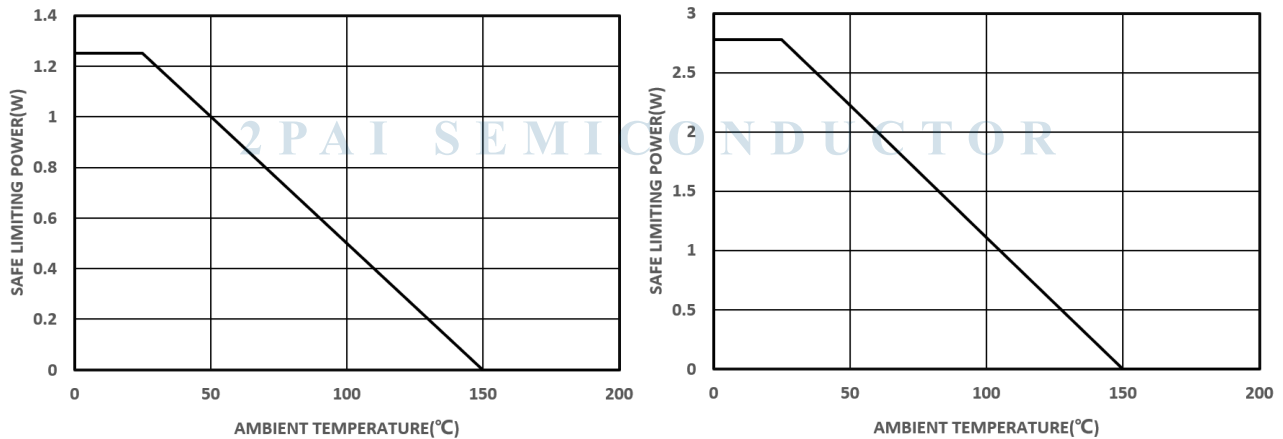

Figure 9. Thermal Derating Curve, Dependence of Safety Limiting Values with Ambient Temperature per VDE (left: $\pi 12xU3x$; right: $\pi 12xU6x$)

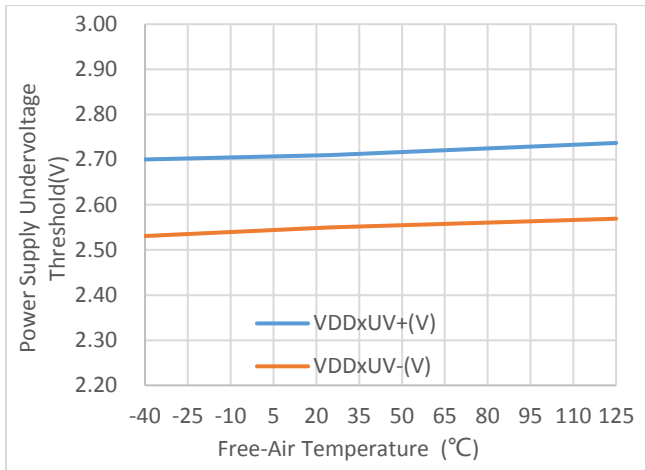

Figure 10. UVLO vs. Free-Air Temperature

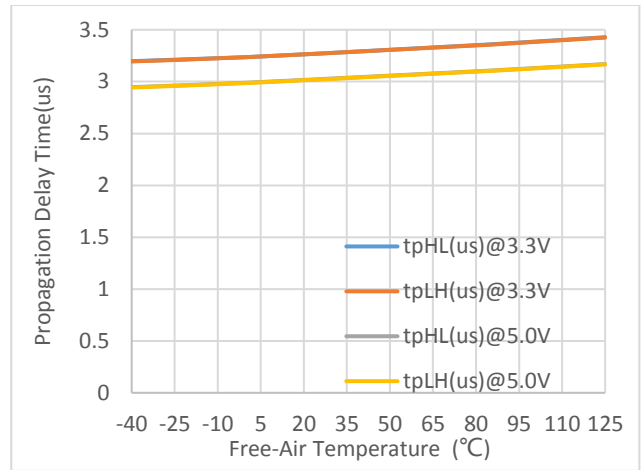

Figure 11. $\pi 12xU3x$ Propagation Delay Time vs. Free-Air Temperature

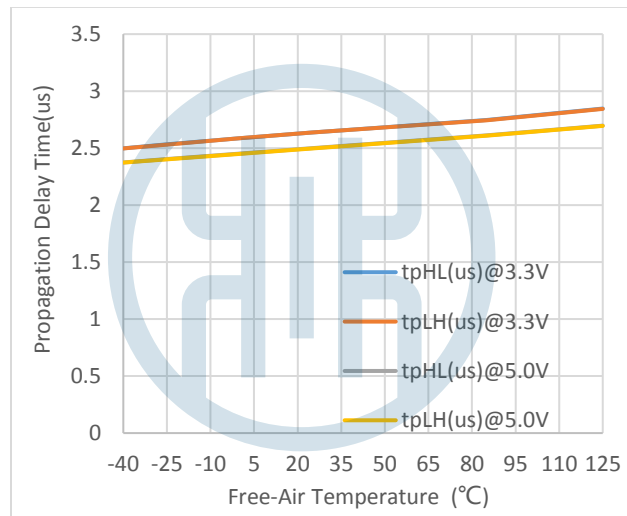

Figure 12. $\pi 12xU6x$ Propagation Delay Time vs. Free-Air Temperature

2PAI SEMICONDUCTOR

Timing test information

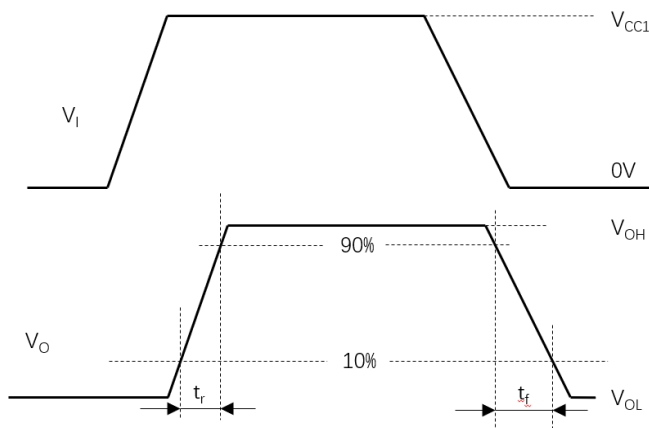

Figure 13. Transition time waveform measurement

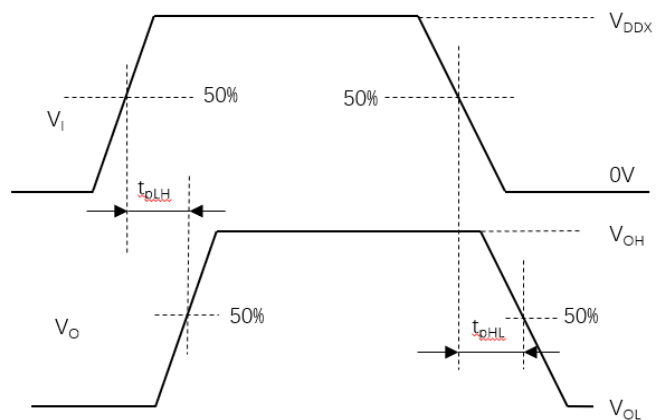

Figure 14. Propagation delay time waveform measurement

APPLICATIONS INFORMATION

OVERVIEW

The π 1xxxx are 2PaiSemi digital isolators product family based on 2PaiSemi unique *iDivider*[®] technology. Intelligent voltage *Divider* technology (*iDivider*[®] technology) is a new generation digital isolator technology invented by 2PaiSemi. It uses the principle of capacitor voltage divider to transmit signal directly cross the isolator capacitor without signal modulation and demodulation. Compare to the traditional Opto-couple technology, icoupler technology, OOK technology, *iDivider*[®] is a more essential and concise isolation signal transmit technology which leads to greatly simplification on circuit design and therefore significantly improves device performance, such as lower power consumption, faster speed, enhanced anti-interference ability, lower noise.

By using matured standard semiconductor CMOS technology and the innovative *iDivider*[®] design, these isolation components provide outstanding performance characteristics and reliability superior to alternatives such as optocoupler devices and other integrated isolators. The π 1xxxx isolator data channels are independent and are available in a variety of configurations with a withstand voltage rating of 1.5 kV rms to 5.0 kV rms and the data rate from DC up to 600Mbps (see the Ordering Guide).

The π 120Uxx/ π 121Uxx/ π 122Uxx are the outstanding 150Kbps dual-channel digital isolators with the enhanced ESD capability. the devices transmit data across an isolation barrier by layers of silicon dioxide isolation.

The devices operate with the supply voltage on either side ranging from 3.0 V to 5.5 V, offering voltage translation of 3.3 V and 5 V logic. The π 120Uxx/ π 121Uxx/ π 122Uxx have very low propagation delay and high speed. The input/output design techniques allow logic and supply voltages over a wide range from 3.0 V to 5.5 V, offering voltage translation of 3.3 V and 5 V logic. The architecture is designed for high common-mode transient immunity and high immunity to electrical noise and magnetic interference.

See the Ordering Guide for the model numbers that have the fail-safe output state of low or high.

PCB LAYOUT

The low-ESR ceramic bypass capacitors must be connected between V_{DD1} and GND_1 and between V_{DD2} and GND_2 . The bypass capacitors are placed on the PCB as close to the isolator device as possible. The recommended bypass capacitor value is between 0.1 μ F and 10 μ F. The user may also include resistors (50–300 Ω) in series with the inputs and outputs if the system is excessively noisy, or in order to enhance the anti ESD ability of the system.

Avoid reducing the isolation capability, Keep the space underneath the isolator device free from metal such as planes, pads, traces and vias.

To minimize the impedance of the signal return loop, keep the solid ground plane directly underneath the high-speed signal path, the closer the better. The return path will couple between the nearest

ground plane to the signal path. Keep suitable trace width for controlled impedance transmission lines interconnect.

To reduce the rise time degradation, keep the length of input/output signal traces as short as possible, and route low inductance loop for the signal path and It's return path.

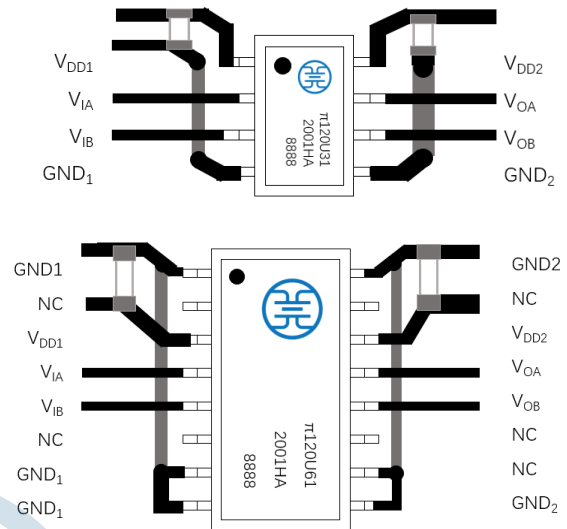

Figure 15. Recommended Printed Circuit Board Layout

CMTI MEASUREMENT

To measure the Common-Mode Transient Immunity (CMTI) of π 1xxxx isolator under specified common-mode pulse magnitude (VCM) and specified slew rate of the common-mode pulse (dVCM/dt) and other specified test or ambient conditions, The common-mode pulse generator (G1) will be capable of providing fast rise and fall pulses of specified magnitude and duration of the common-mode pulse (VCM), such that the maximum common-mode slew rates (dVCM/dt) can be applied to π 1xxxx isolator coupler under measurement. The common-mode pulse is applied between one side ground GND_1 and the other side ground GND_2 of π 1xxxx isolator, and shall be capable of providing positive transients as well as negative transients.

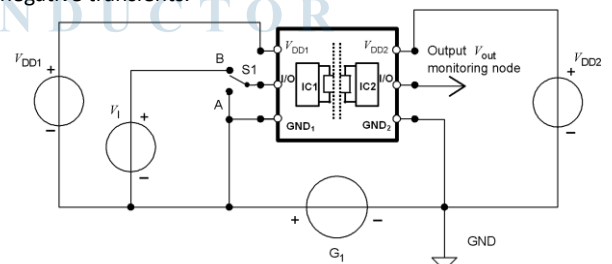
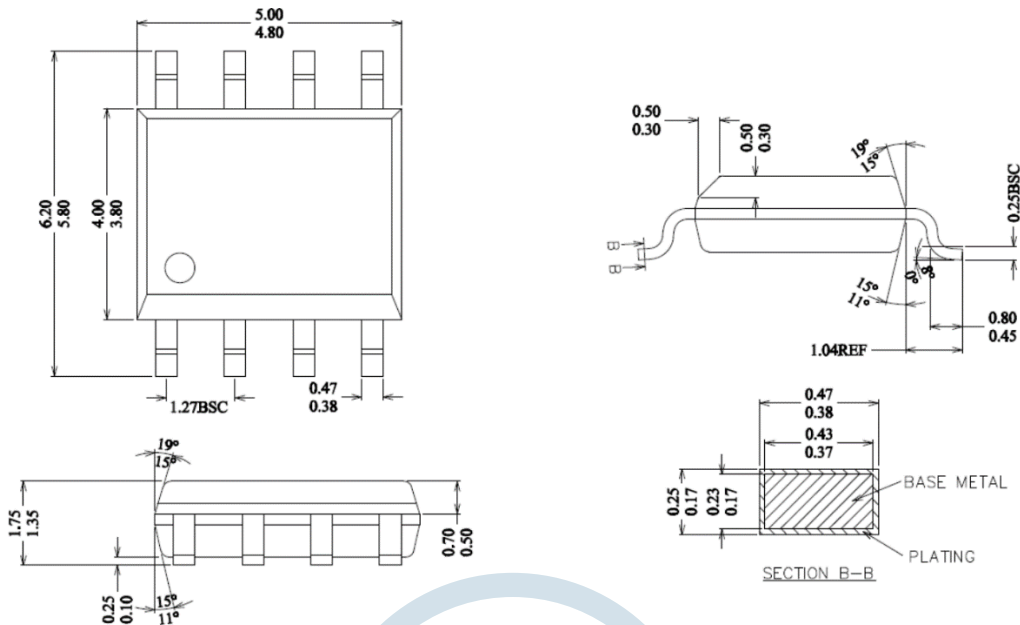

Figure 16. Common-mode transient immunity (CMTI) measurement

OUTLINE DIMENSIONS



NOTES:
ALL DIMENSIONS REFER TO JEDEC STANDARD MS-012 AA
DO NOT INCLUDE MOLD FLASH OR PROTRUSION.

Figure 17. 8-Lead Narrow Body SOIC [NB SOIC-8] Outline Package –dimension unit(mm)

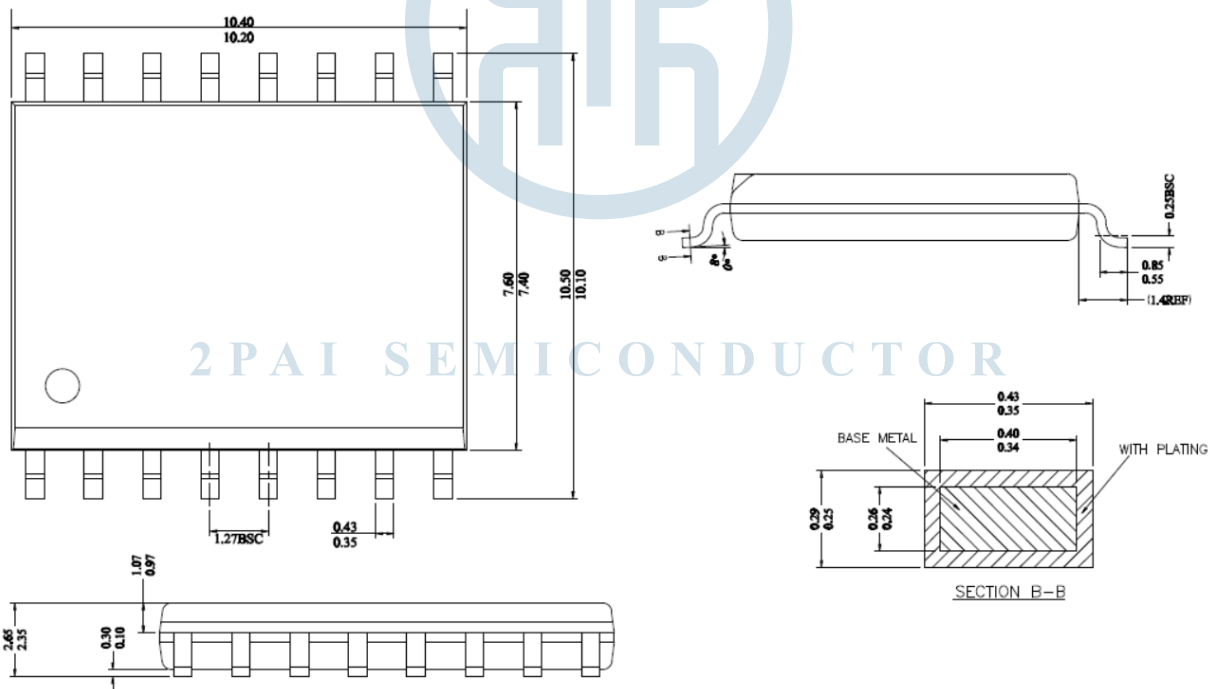

NOTES:

ALL DIMENSIONS MEET JEDEC STANDARD MS-013 AA
DO NOT INCLUDE MOLD FLASH OR PROTRUSIONS.

Figure 18. 16-Lead Wide Body Outline Package [16-Lead SOIC_W] –dimension unit(mm)

Land Patterns

8-Lead Narrow Body SOIC [NB SOIC-8]

The figure below illustrates the recommended land pattern details for the π 1xxxxx in an 8-pin narrow-body SOIC. The table below lists the values for the dimensions shown in the illustration.

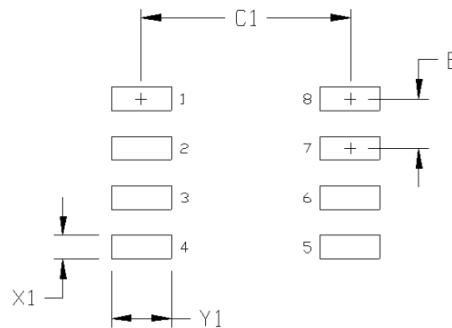

Figure 19. 8-Lead Narrow Body SOIC [NB SOIC-8] Land Pattern

Table 19. 8-Lead Narrow Body SOIC Land Pattern Dimensions

Dimension	Feature	Parameter	Unit
C1	Pad column spacing	5.40	mm
E	Pad row pitch	1.27	mm
X1	Pad width	0.60	mm
Y1	Pad length	1.55	mm

Note:

- 1.This land pattern design is based on IPC -7351.
- 2.All feature sizes shown are at maximum material condition and a card fabrication tolerance of 0.05 mm is assumed.

16-Lead Wide Body SOIC [WB SOIC-16]

The figure below illustrates the recommended land pattern details for the π 1xxxxx in a 16-pin wide-body SOIC package. The table lists the values for the dimensions shown in the illustration.

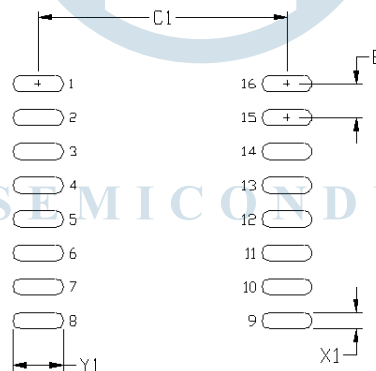

Figure 20. 16-Lead Wide Body SOIC [WB SOIC-16] Land Pattern

Table 20. 16-Lead Wide Body SOIC [WB SOIC-16] Land Pattern Dimensions

Dimension	Feature	Parameter	Unit
C1	Pad column spacing	9.40	mm
E	Pad row pitch	1.27	mm
X1	Pad width	0.60	mm
Y1	Pad length	1.90	mm

Note:

- 1.This land pattern design is based on IPC -7351
- 2.All feature sizes shown are at maximum material condition and a card fabrication tolerance of 0.05 mm is assumed.

Top Marking

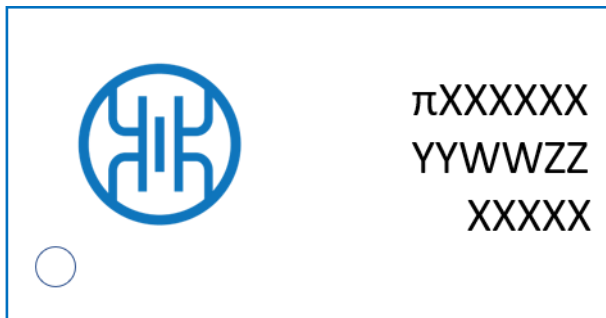

Line 1	π xxxxxx=Product name
Line 2	YY = Work Year WW = Work Week ZZ=Manufacturing code from assembly house
Line 3	XXXXX, no special meaning

REEL INFORMATION

8-Lead Narrow Body SOIC [NB SOIC-8]

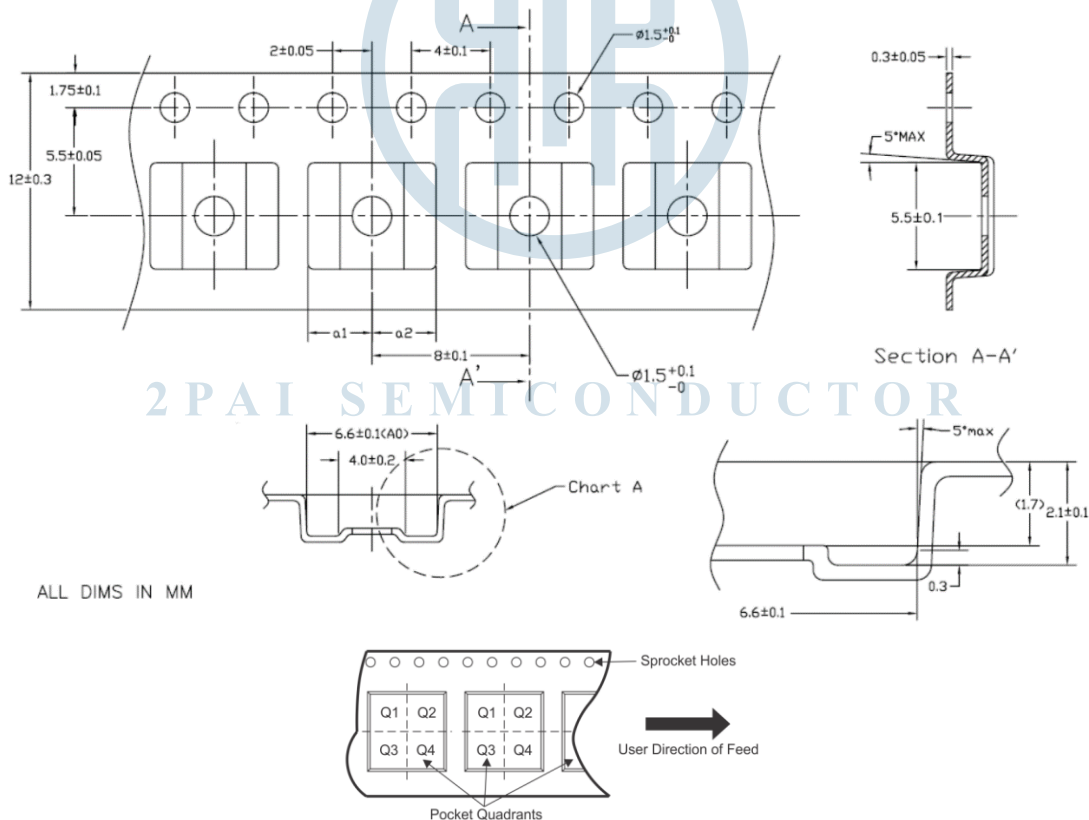

2PAI SEMICONDUCTOR

Figure 21. 8-Lead Narrow Body SOIC [NB SOIC-8] REEL INFORMATION—dimension unit(mm)

16-Lead Wide Body SOIC [WB SOIC-16]

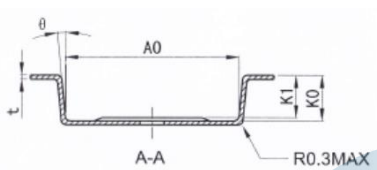
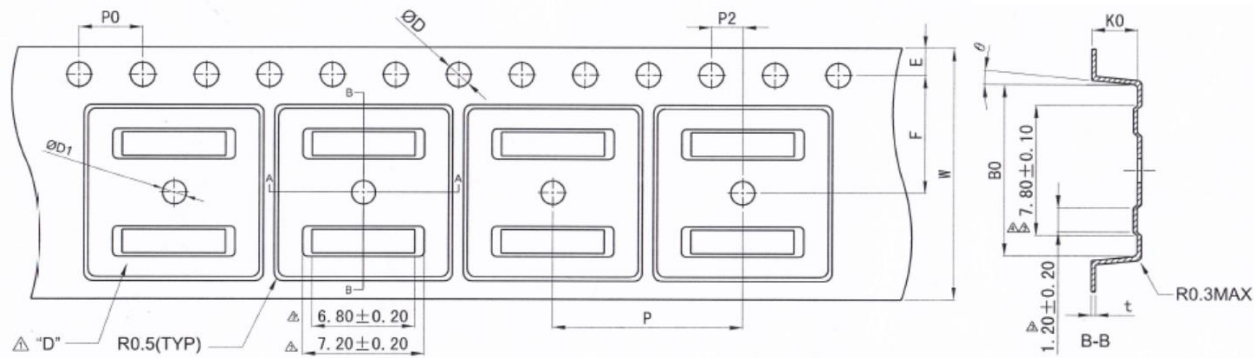

Items	Size(mm)	Items	Size(mm)
E	1.75±0.10	W	16.00±0.30
F	7.50±0.05	P	12.00±0.10
P2	2.00±0.05	A0	10.90±0.10
D	1.55±0.05	B0	10.80±0.10
D1	1.5±0.10	K0	3.00±0.10
P0	4.00±0.10	t	0.30±0.05
10P0	40.00±0.20	K1	2.70±0.10
		θ	5° TYP

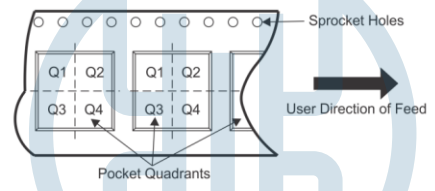

Note: The Pin 1of the chip is in the quadrant Q1

Figure 22. 16-Lead Wide Body SOIC [WB SOIC-16] REEL INFORMATION

ORDERING GUIDE

Table 21. ORDERING GUIDE

Model Name ¹	Temperature Range	No. of Inputs, V _{DD1} Side	No. of Inputs, V _{DD2} Side	Isolation Rating (kV rms)	Fail-Safe Output State	Package	MSL Peak Temp ²	MOQ/Quantity per reel ³
π 120U31	-40~125°C	2	0	3	High	NB SOIC-8	Level-2-260C-1 YEAR	4000
π 120U30	-40~125°C	2	0	3	Low	NB SOIC-8	Level-2-260C-1 YEAR	4000
π 121U31	-40~125°C	1	1	3	High	NB SOIC-8	Level-2-260C-1 YEAR	4000
π 121U30	-40~125°C	1	1	3	Low	NB SOIC-8	Level-2-260C-1 YEAR	4000
π 122U31	-40~125°C	1	1	3	High	NB SOIC-8	Level-2-260C-1 YEAR	4000
π 122U30	-40~125°C	1	1	3	Low	NB SOIC-8	Level-2-260C-1 YEAR	4000
π 120U61	-40~125°C	2	0	5	High	WB SOIC-16	Level-2-260C-1 YEAR	1500
π 120U60	-40~125°C	2	0	5	Low	WB SOIC-16	Level-2-260C-1 YEAR	1500
π 121U61	-40~125°C	1	1	5	High	WB SOIC-16	Level-2-260C-1 YEAR	1500
π 121U60	-40~125°C	1	1	5	Low	WB SOIC-16	Level-2-260C-1 YEAR	1500
π 122U61	-40~125°C	1	1	5	High	WB SOIC-16	Level-2-260C-1 YEAR	1500
π 122U60	-40~125°C	1	1	5	Low	WB SOIC-16	Level-2-260C-1 YEAR	1500

Note :

¹ Pai1xxxxx is equals to π 1xxxxx in the customer BOM
² MSL, Peak Temp. - The Moisture Sensitivity Level rating according to the JEDEC industry standard classifications, and peak solder temperature.
³ MOQ, minimum ordering quantity.

PART NUMBER NAMED RULE

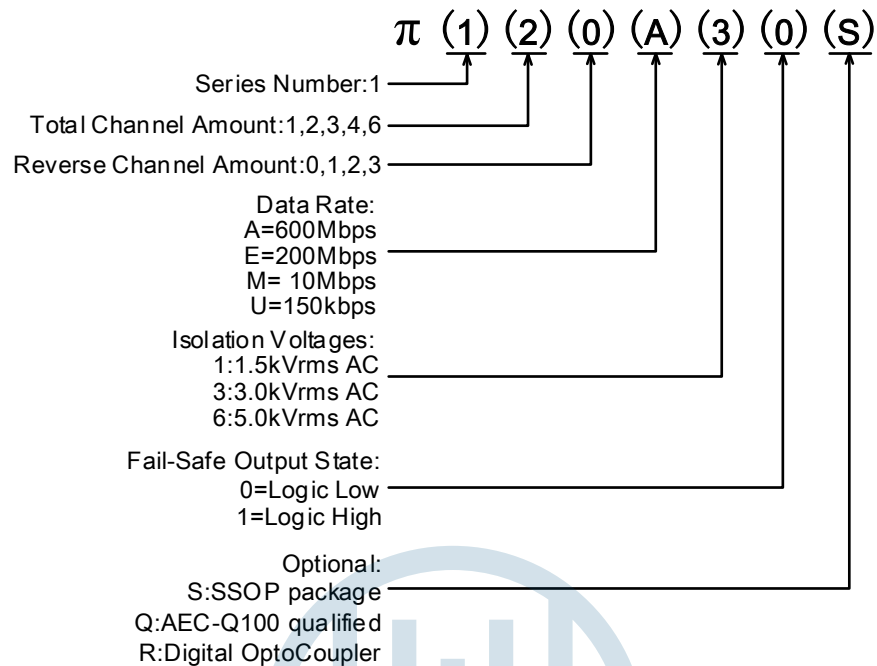

Notes:

π 1xxxxx is equals to π 1xxxxx in the customer BOM

IMPORTANT NOTICE AND DISCLAIMER

2PaiSemi intends to provide customers with the latest, accurate, and in-depth documentation. However, no responsibility is assumed by 2PaiSemi for its use, nor for any infringements of patents or other rights of third parties that may result from its use. Characterization data, available modules, and "Typical" parameters provided can and do vary in different applications. Application examples described herein are for illustrative purposes only. 2PaiSemi reserves the right to make changes without further notice and limitation to product information, specifications, and descriptions herein, and does not give warranties as to the accuracy or completeness of the included information. 2PaiSemi shall have no liability for the consequences of use of the information supplied herein.

Trademarks and registered trademarks are the property of their respective owners. This document does not imply, or express copyright licenses granted hereunder to design or fabricate any integrated circuits.

Room 307-309, No.22, Boxia Road, Pudong New District, Shanghai, 201203, China 021-50850681

2Pai Semiconductor Co., Limited. All rights reserved.

<http://www.rpsemi.com/>

REVISION HISTORY

Revision	Date	Page	Change Record
1.0	2018/09/17	All	Initial version
1.1	2018/11/28	P11	Changed the recommended bypass capacitor value.
1.2	2019/09/08	Page1	Changed the contact address. Add <i>iDivider</i> technology description in General Description. Changed propagation delay time, CMTI and HBM ESD. Added WB SOIC-16 Lead information.
1.3	2019/12/20	Page1,11,14	Changed description of π 1xxx6x.
1.4	2020/02/16	Page1	Changed propagation delay time.
1.5	2020/02/25	Page5	Changed Pulse Width Distortion.
1.6	2020/03/16	Page6	Changed VDDx Undervoltage Threshold and Regulatory Information. Added information of Land Patterns and Top Marking
1.7	2020/04/16	Page12	Optimize description and format to make it consistent with the Chinese version.
1.8	2021/05/17	Page 1,5~10	Changed Regulatory Information. Added propagation delay time and supply current of π 1xxU6x.
1.9	2021/12/06	Page14,15	Changed Top Marking Information. Changed MSL Peak Temp.



2PAI SEMICONDUCTOR